

**Series 18 Draw Winch** data sheet

<b>draw winch</b>	<b>18-00-100</b>
<b>tensioning assembly</b>	<b>18-00-101</b>
<b>limit assembly</b>	<b>18-00-102</b>

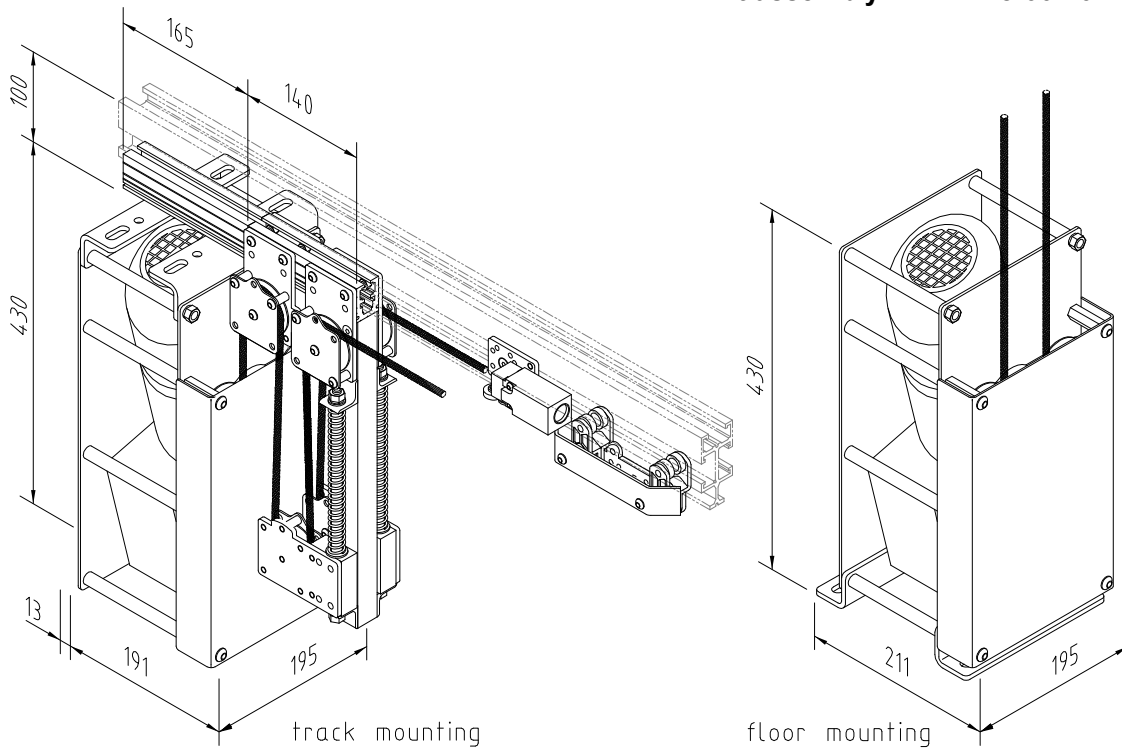

**Standard Specification**

Motor power	0.18kW
Supply voltage	415V 3Ph (240 V 3PhΔ variable speed controller)
Supply frequency	50 Hz (10 – 200 Hz variable speed controller)
Supply current	0.6 A/Phase
Draw speed	0.45m/s (at 50Hz) other speeds available
Draw load	30kgf (at 50Hz)
Rope size	6mm 16 plait polyester (non stretch core recommended)
Draw length	limited only by load
Limit arrangement	direct strike – other variations available on request

The series 18 motor unit has been designed to overcome the reliability issues of helical drum wire rope systems. A switch to fibre draw lines means quieter operation (Spectra and Dyneena cored ropes have higher tensile strength and less stretch than similar diameter wire ropes). The traction drive and tensioning system do not rely on precise motor placement and minimum fleet angles and thus eliminate potential for crossed rope and groove tracking problems. For safety and to conserve floor space, the motor unit can be mounted directly to the track.

Non-standard winch variants can be quickly assembled – the standard components allow for fitting of a brake (0.18kW motor) or up to a 0.37kW motor (accepts D63 & 71 motor frames). Motor, gearbox ratios and traction pulleys can be selected to suit other applications such as screen masking or high speed applications.

Limit set up is quick and precise. Standard mounting brackets allow positioning at any point on the tracks. Standard cover strips allow limit switch cabling to be run in the track extrusion, providing mechanical protection and a very tidy installation.

## Series 18 Draw Winch

### Control options:

#### Single phase (variable speed) inverter drive 18-00-110

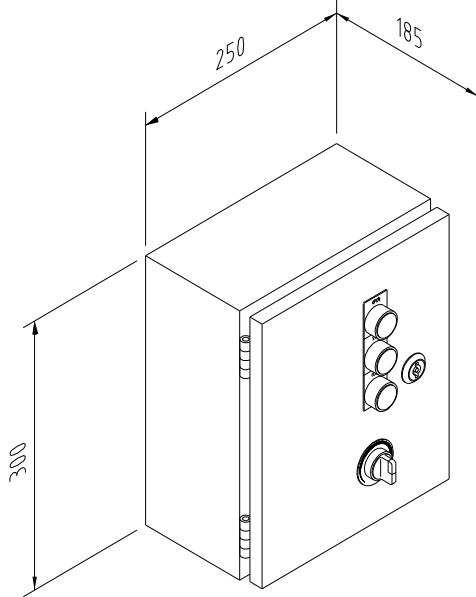

#### Specification

Motor power	0.18kW
Supply voltage	240V 1Ph
Supply frequency	50 Hz
Supply current	3A
Output voltage	230 V 3PhΔ
Output frequency	0.1 -200 Hz
Output current	1.4A (rms)/Ph

#### Standard drive settings

Output frequency	20 -65 Hz
Draw speed	0.18 - 0.60 m/s
Acceleration time	0.3 sec
Deceleration time	0.3 sec

Single phase (variable speed) inverter drive. The panel is housed in an IP55 powder coated steel enclosure. This option supplies 230VAC 3 phase and variable frequency (standard setting range 20-60Hz though 0-200Hz is available). A full size rotary variable speed control knob is provided on the panel front (if required this may be disabled to prevent tampering and instead frequency can be set inside the panel). Panel mounted push buttons are configured as standard for "push and run" (latching contacts), removal of an internal link will convert operation to "push and hold to run" (momentary contacts). The standard control unit will also accept one or more remote pushbutton stations.

Additionally, the drive also allows:

Regenerative and DC injection braking, allowing for controlled rapid stopping.

Adjustable acceleration and deceleration times.

Provision for an alternative external signal to control output frequency (potentiometer as supplied) or 0 - 10 V DC, 0 - 20 mA DC, or 4 - 20 mA DC.

Settable upper and lower frequency limits.

Analogue output voltage, providing connections for an analogue voltage output (0 - 10 V DC), proportional to the output frequency. (Optional panel mount LCD speed indication display available)

Multifunction output relay, providing normally open relay contacts for indication of "run", "frequency reached", or "fault". (optional panel mount indicator light available)

Multifunction control inputs, providing selection of up to three preset speeds. (optional panel mount three position speed switch available)

Over-voltage and under-voltage protection, shuts down the drive if the AC line voltage goes above or below the operating range.

Regeneration protection, eliminating tripping due to bus over-voltage caused by rapid deceleration of high inertial loads.

Stall protection, prevents the motor from stalling during startup of high inertial loads.

Electronic motor overload protection ( $I^2t$ ), preventing motor burnout and eliminates nuisance tripping due to overload.

Over-temperature protection, shuts down the drive if the temperature exceeds safe limits.

## Series 18 Draw Winch

### Control options:

#### Three phase reversing contactor panel

**18-00-111**

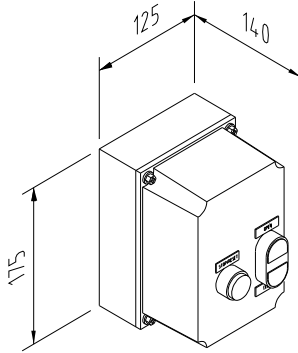

#### Specification

Motor power	0.18kW
Supply voltage	415V 3Ph
Supply frequency	50 Hz
Starter type	DOL
Coil voltage	240V AC
Overload current rating	0.55 – 0.8 A

Three-phase reversing contactor panel with adjustable thermal overload relay. The panel is housed in a compact IP40 fully insulated polycarbonate enclosure. This option supplies mains voltage and frequency (415VAC @ 50Hz). Panel mounted push buttons are configured as standard for “push and run” (latching contacts), removal of an internal link will convert operation to “push and hold to run” (momentary contacts). The standard control unit will accept one or more remote pushbutton stations.

#### Remote push button station

**18-00-112**

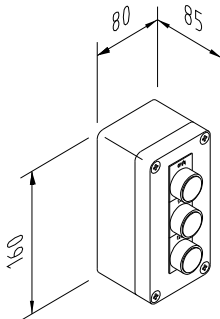

#### Specification

Rated voltage	240V AC
Contacts	open NO
	stop NC
	close NO

Remote push button station. The push button station is housed in a IP40 fully insulated polycarbonate enclosure, as with all options the unit is fitted with industrial quality switches for reliability and durability. This option suits both single and three phase control options.

#### Custom control options

All control options can be customised to accommodate interface with DMX or other proprietary control systems. RF and IR options can also be accommodated. Mechanical and control systems are flexible and can be readily adapted to suit most applications.